	ITEM: TIPOUT-SS		MATERIAL:		
	FINISH:		WEIGHT: 9		
<b>PROPRIETARY AND CONFIDENTIAL</b> THE INFORMATION CONTAINED IN THIS DRAWING IS THE SOLE PROPERTY OF HARDWARE RESOURCES INC. ANY REPRODUCTION IN PART OR AS A WHOLE WITHOUT THE WRITTEN PERMISSION OF HARDWARE RESOURCES INC. IS PROHIBITED.	TOLERANCE UNLESS OTHERWISE SPECIFIED:		UNIT:	DRAWN BY: <i>alan.liu</i>	DATE:
	X: MM ±0.20	X.X: MM ±0.10	SIZE:	CHECKED BY:	DATE:
	X.XX: MM ±0.05	ANGULAR: ±0.5°	APPROVED BY:		DATE:
	DO NOT SCALE DRAWING				
			PROJECTION: 		

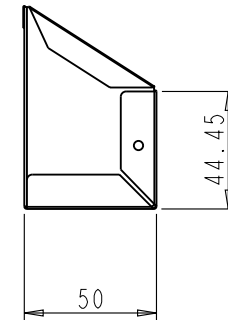

FRONT VIEW

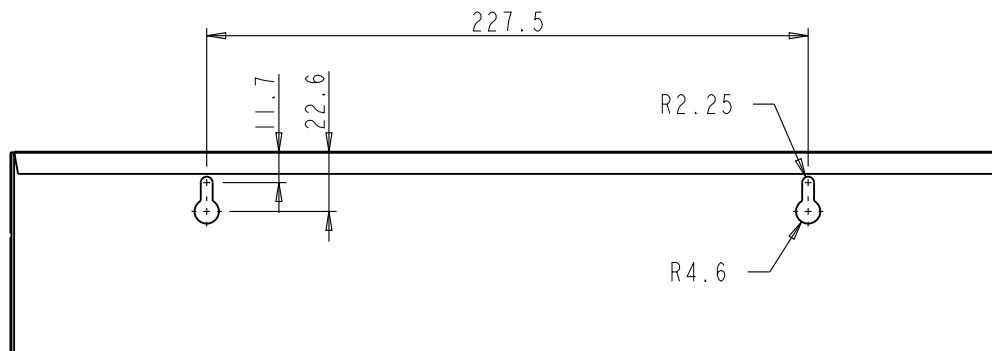

SIDE VIEW



REAR VIEW

Note:

The thickness of sheetmetal is 0.4MM

	ITEM: TIPOUTSS-14		MATERIAL: STAINLESS STEEL		
	FINISH:		WEIGHT: 244.5 g		
<b>PROPRIETARY AND CONFIDENTIAL</b> THE INFORMATION CONTAINED IN THIS DRAWING IS THE SOLE PROPERTY OF HARDWARE RESOURCES INC. ANY REPRODUCTION IN PART OR AS A WHOLE WITHOUT THE WRITTEN PERMISSION OF HARDWARE RESOURCES INC. IS PROHIBITED.	TOLERANCE UNLESS OTHERWISE SPECIFIED: X : MM ±0.20 X.X : MM ±0.10 X.XX : MM ±0.05 ANGULAR: ±0.5° DO NOT SCALE DRAWING		UNIT: SIZE:	DRAWN BY: <i>alan.liu</i>	DATE:
			CHECKED BY:	DATE:	
			APPROVED BY:	DATE:	

FLATTEN STATUS

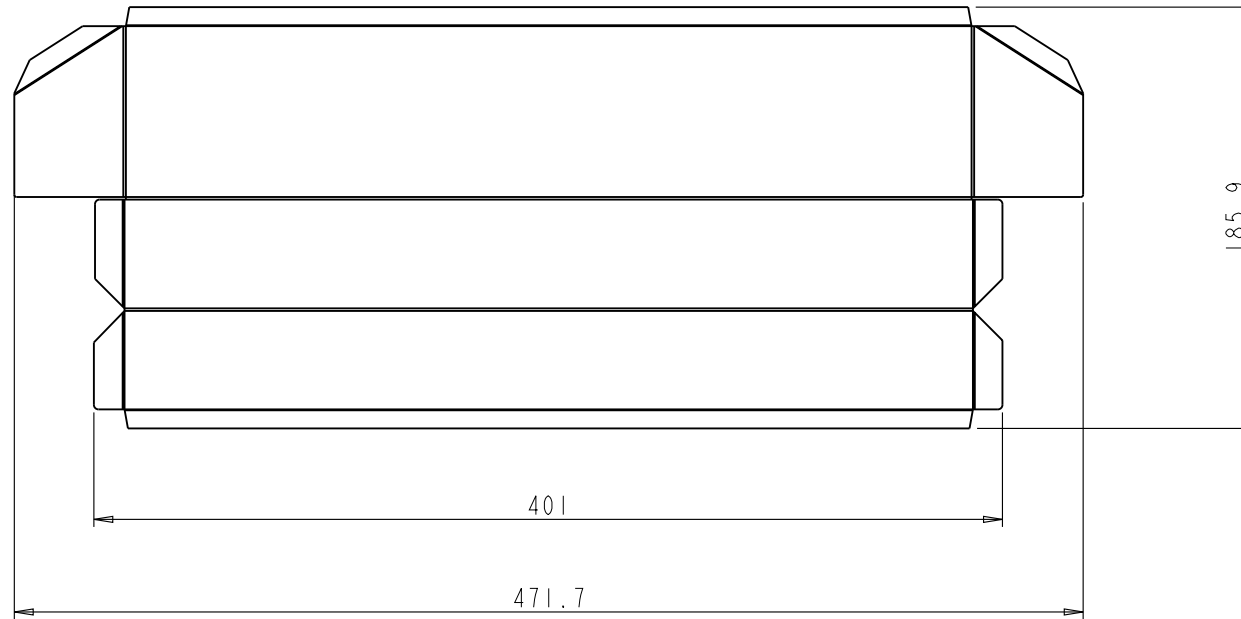

BEND STATUS

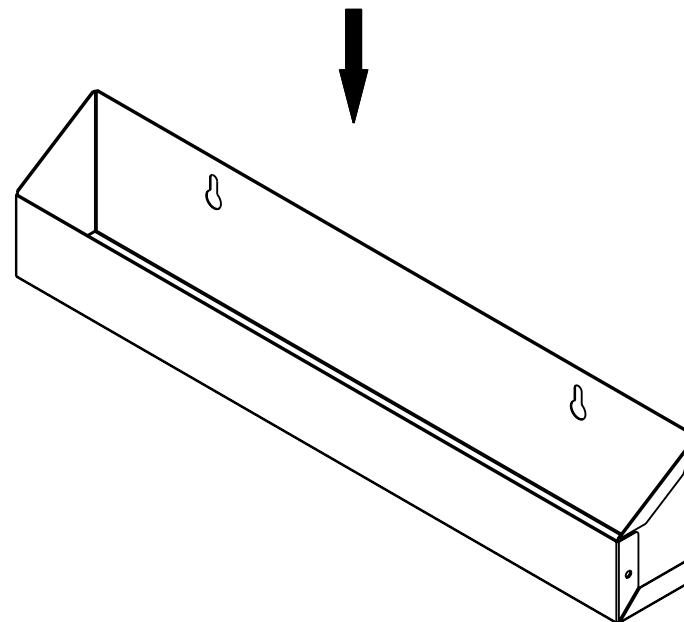

Note:

The thickness of sheetmetal is 0.4MM

	ITEM#: TIPOUTSS-14		MATERIAL: STAINLESS STEEL	
	FINISH:		WEIGHT: 244.5 g	
<p><b>PROPRIETARY AND CONFIDENTIAL</b></p> <p>THE INFORMATION CONTAINED IN THIS DRAWING IS THE SOLE PROPERTY OF HARDWARE RESOURCES INC. ANY REPRODUCTION IN PART OR AS A WHOLE WITHOUT THE WRITTEN PERMISSION OF HARDWARE RESOURCES INC. IS PROHIBITED</p>	TOLERANCE UNLESS OTHERWISE SPECIFIED:		PROJECTION:	
	X: MM ±0.20	UNIT:	DRAWN BY: <i>alan.liu</i>	
	X.X: MM ±0.10	SIZE:	CHECKED BY:	
	X.XX: MM ±0.05	APPROVED BY:	DATE:	
ANGULAR: ±0.5°				
DO NOT SCALE DRAWING				